



SX-2 Specifications & Options

ENGINE

- Tier 4f, Cummins® QSL9 380 hp (283 kW) @ 2,100 rpm

WEIGHT

- Shipping weight..... 42,000 lbs (19,050 kg)
- Operating weight 44,000 lbs (19,958 kg)

ELECTRICAL SYSTEM

- CAN-bus serial communication systems for superior performance, reduced wiring, increased reliability & improved service and maintenance features.

PROPEL SYSTEM

- 2-speed hydrostatic drive
- 2-wheel rear drive with differential lock

SPEED

- Travel: 6 mph (10 kph)
- Work: 150 fpm & 300 fpm

TIRES

- Heavy-duty, single-piece wheels prevent rim slippage and tire failure. Rear: 23.5-25 Front: 15.5-25

STEERING

- Joy stick-controlled. Front steering.
- Turning radius 10' (3,048 mm) in cut.

OPERATOR STATION

- Fully enclosed and pressurized with A/C and heating system (optional)
- Fixed cab / right side flush mounted

INJECTION SYSTEM

- Water or emulsion
- Up to 500 gpm (1,893 lpm)

CUTTER SYSTEM

- High efficiency / high torque hydrostatic drive
- 2 Planetary gearboxes

CUTTER

- Right-hand flush cut
- Cutting width 78" (2,000 mm)
- Cutting depth..... 18" (457 mm)
with 50" drum (1,270 mm)

CUTTER SPEEDS

- Variable - 80 to 160 rpm



SERVICE CAPACITIES

- Fuel Tank 170 gal (644 l)
- Hydraulic Fluid Tank..... 80 gal (303 l)

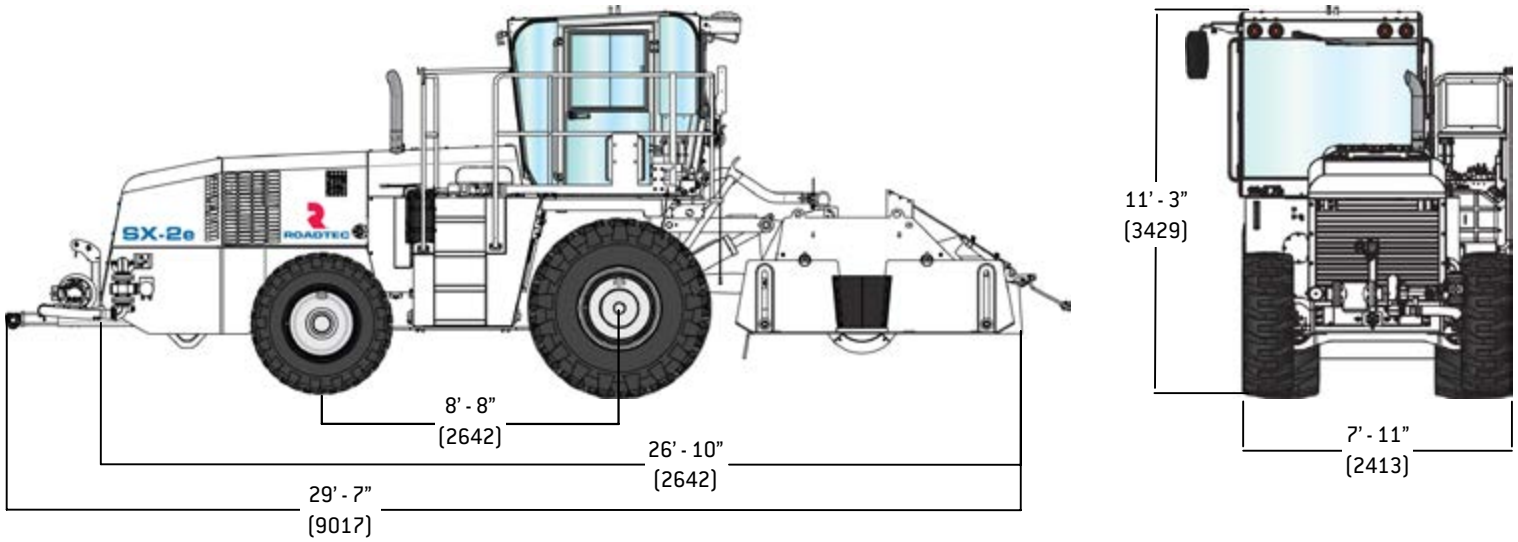

Dimensions in brackets are mm.

Specifications are subject to change without notice.

ROADTEC an Astec Industries Company

800 MANUFACTURERS RD • CHATTANOOGA, TN 37405 USA • 800.272.7100 • FAX 423.267.7104 • roadtec.com



© 2013 Roadtec, Inc. All Rights Reserved